



ISO9001:2015  
ISO18001:2015  
ISO14001:2007

# Ti - BASED CERMET



ZHAOQIANG  
THE PIONEER OF CERMET PARTS



Tel: 028-81185678





Fax: 0813-3202098

Web: <http://www.zqtkj.com/>

Address: 8th Floor, Maipu Building, Tianfu 3rd Street, High tech Zone, Chengdu, Sichuan Province

Official Website Wechat Official Account



-  Wear Resistance
-  Corrosion Resistance
-  High Temperature Resistance
-  Antioxidant
-  Self Lubrication



## Company

Sichuan Zhaoqiang Titanium Magnetic Technology Co., Ltd, a high-tech enterprise, is mainly engaged in the R&D of new materials for magnetic fluids and Ti-based metal ceramics. The company is currently headquartered in Chengdu High tech Zone and has two wholly-owned subsidiaries – Zigong Zhaoqiang Sealing Products Industrial Co., Ltd and Sichuan New Titanium Hui Innovation Materials Co., Ltd.

The company is at an internationally advanced and domestically leading level in the R&D and manufacturing of magnetic fluid material products. At the same time, applied new Ti-based metal ceramic materials in the fields of wear resistance, corrosion resistance, and high temperature resistance industry. Product performance (toughness, bending strength, density) is industry-leading.

Since its establishment in 2000, the company has obtained more than 70 national patents, including 12 invention patents. The company has 16 provincial-level scientific and technological innovation projects, two national torch program projects, and two national key new product projects. It has successively won the first prize of the Ministry of Education's Science and Technology Progress Award, the second prize of the National Technology Invention Award, and the first prize of the China Machinery Industry Science and Technology Award. In 2023, it was awarded the national Specialization, Refinement, Uniqueness, Innovative "Little Giant" Enterprise, and was recognized as the "Sichuan Province Enterprise Technology Center". Meanwhile, the company is also a national high-tech enterprise, a famous trademark in Sichuan Province, a member unit of the National Machinery Sealing Association, and has the qualification certificate for national defense weapon equipment research and development and confidentiality.

The company mainly provides customers sealing solutions and new Ti-based cermet materials. Its products are widely used in aerospace, national defense and military industry, petroleum and petrochemical, mechanical metallurgy, power, steel, chemical industry, shipbuilding, medicine and other industries. It has established long-term and stable cooperative relationships with leading enterprises in various fields and has been unanimously recognized by customers.

Company Profile	02
Qualification	04
Ti-Based Cermet Profile	05
Ti-Based Cermet Spray Powder	08
Ti-Based Cermet Wear Resistant Parts	09
Ti-Based Cermet Valve & Fittings	11
Notes For Non-standard Products	14

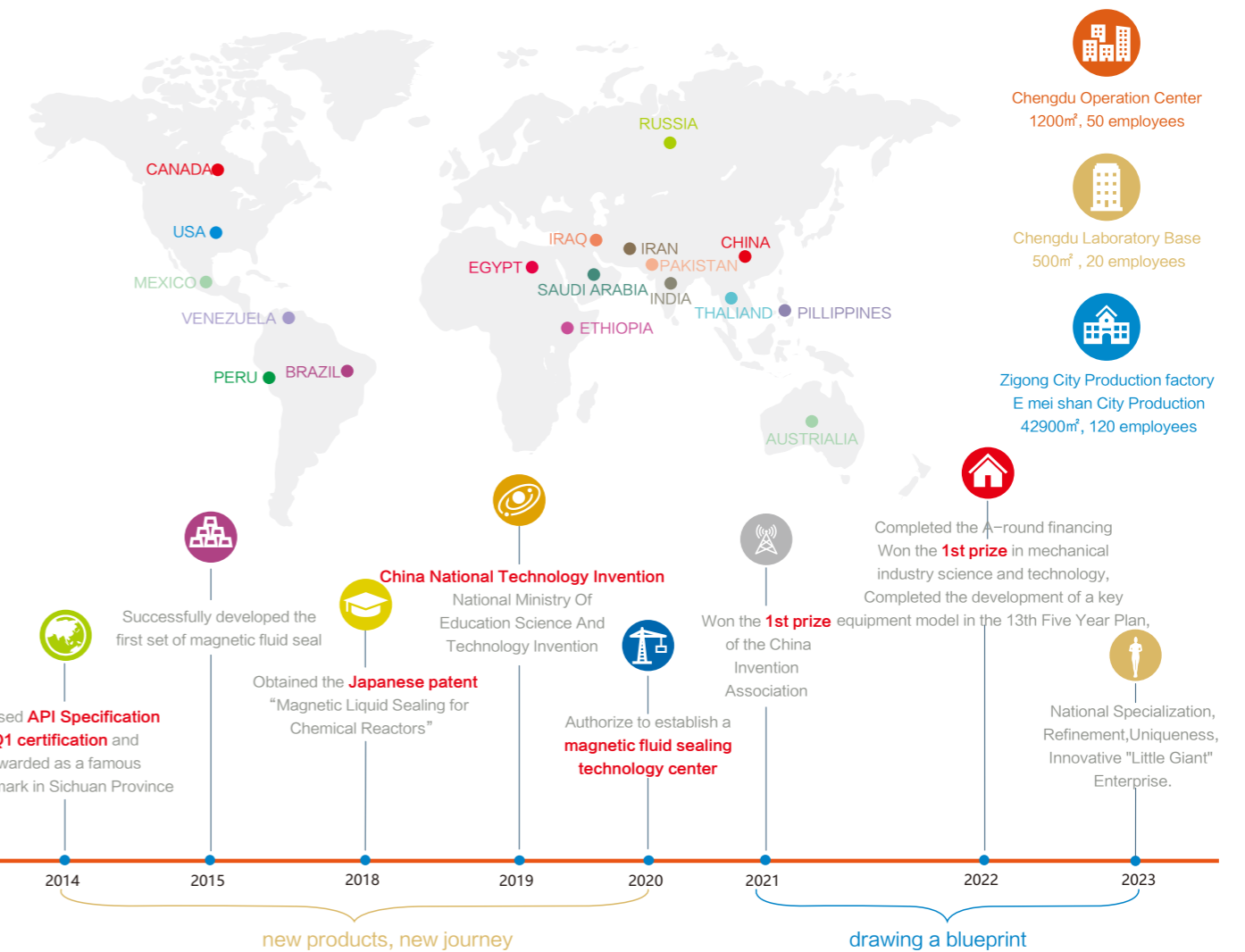

## Development History

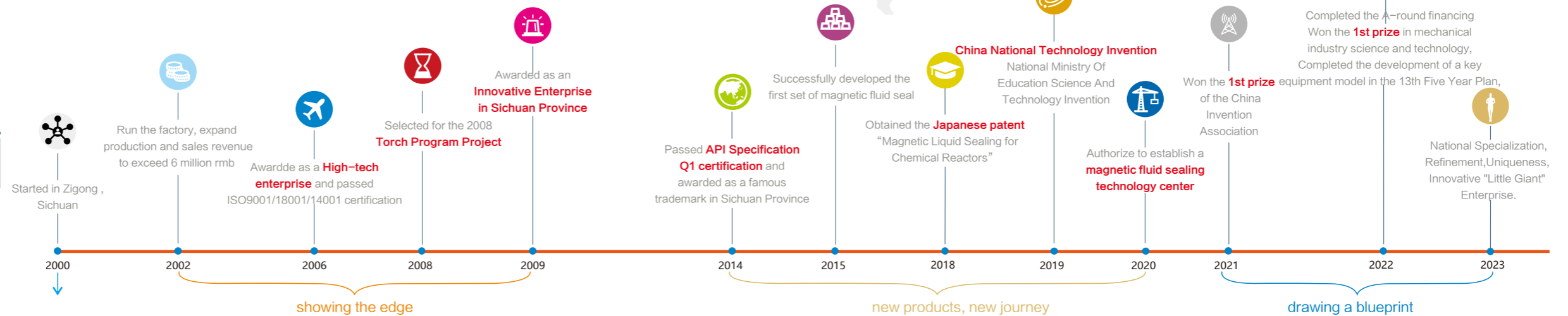

# Clients



# Qualifications

China National Technology Invention Award



High-tech Enterprise



API Q1



16项

invention patents



46项

Utility model patents



Japanese invention patent Education Science & Technology Invention



ISO9001

ISO18001

ISO14001



# TI-BASED CERMET PROFILE

Ti-based metal ceramics are composite materials made by sintering ceramic hard phase and metal bonding phase through powder metallurgy process. It has the characteristics of high hardness, high wear resistance, corrosion resistance, high temperature resistance, and oxidation resistance of ceramic materials, as well as the good toughness, physical conductivity, and thermal conductivity of metal materials. Meanwhile, its density is less than half of that of tungsten steel, and it has a huge cost advantage under the same quality; Titanium resources are abundant, which can save tungsten mining and increase strategic reserves of rare metals. It is currently widely recognized internationally as a new material to replace tungsten cobalt hard alloys.

## Development History of Metal Ceramics

Tungsten carbide and cobalt carbide are the earliest metal ceramics material, but due to the shortage of tungsten and cobalt resources, tungsten free metal ceramics have been developed and have gone through three generations so far:

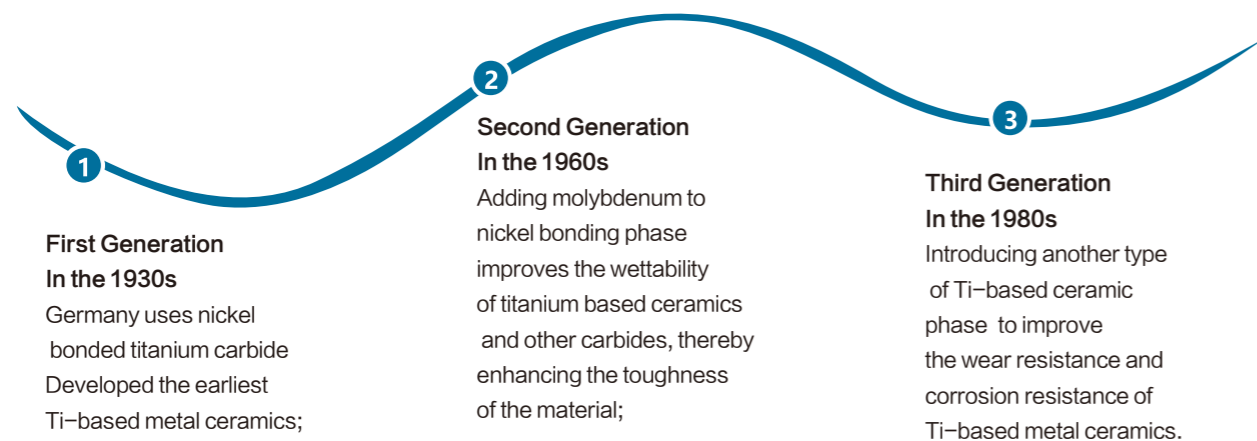

# TI-BASED CERMET GRADES

Grade	Density (g/cm <sup>3</sup> )	Hardness (20 °C)	Bending (N/mm <sup>2</sup> )	Material feature and uses
ZQQ10XN	7.0~7.3	≥ 86.5	≥2800	Good wear resistance, high strength, suitable for mining drill bits, drill heads, and mining machinery cutting teeth.
ZQQ20XN	6.5~6.8	≥ 87.5	≥2600	Good wear resistance and corrosion resistance, suitable for corrosion-resistant submersible pump parts, guide wheels, roller rings, etc.
ZQQ20XN-1	6.9~7.2	≥ 89	≥2500	Wear resistant, corrosion-resistant, with good thermal shock resistance, non-magnetic, suitable for oil well pump valve balls, valve seats, valve needles, etc.
ZQQ30XN	6.6~6.8	≥ 91	≥1800	Excellent corrosion resistance, erosion resistance, suitable for special-shaped structural accessories with high corrosion resistance.
ZQQ30XN-1	6.5~6.7	≥ 92	≥1700	Excellent wear resistance, suitable for conventional and deep-sea submersible electric pump parts and anti erosion mechanical accessories.

# COMPARISON OF HARDNESS PROPERTIES

Performance	Unit	(Al <sub>2</sub> O <sub>3</sub> )	(ZrO <sub>2</sub> )	(SiC)	(Si <sub>3</sub> N <sub>4</sub> )	(WC)	Ti-Based cermet
Density	g/cm <sup>3</sup>	3.7-3.9	5.35-6.0	2.65-3.15	2.4-2.5	13.5-15	6.2~7.9
Hardness	HRA	85-93	85-91	87-95	89-95	93Max	86~95
Bending Strength	Mpa	280-360	900-1150	150-550	165-200	1500-3200	1200~3000

- **Low density:** The density is only 48% of tungsten cobalt hard alloy, and the energy consumption during equipment operation is reduced by at least 30%. The quantity of products per unit weight is 207% of tungsten cobalt hard alloy.
- **High strength:** Compared to alumina, silicon carbide, etc., its bending strength is more than 3.5 times higher.

## High temperature resistance test

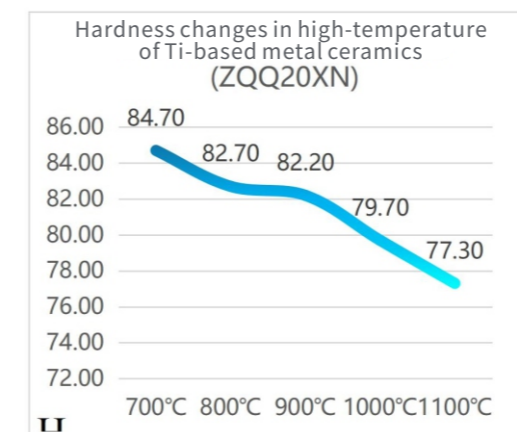

- The high temperature resistance performance of tungsten cobalt hard alloy significantly decreases at 600 °C, while the hardness of Ti-based products decreases significantly when the temperature reaches 1200 °C,

## Friction performance test

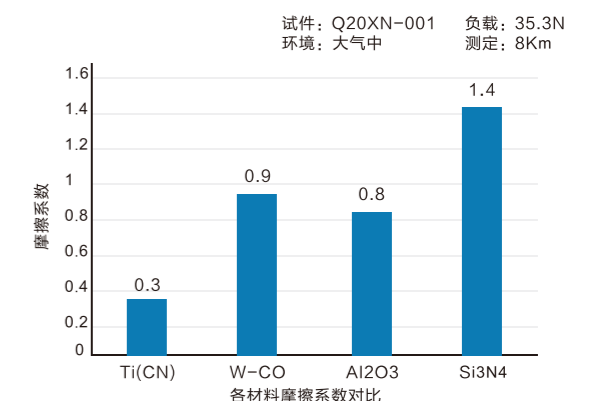

- Wear resistance, equivalent hardness, self-lubrication, friction coefficient of 1/3 of tungsten cobalt hard alloy, longer service life

# CORROSION RESISTANCE TESTING

Experimental Grade

ZQQ20XN VS YG6

Sample Size

15mm\*15mm\*15mm / 5mm\*5mm\*16mm

Acid concentration

5%、10%、20%、30%

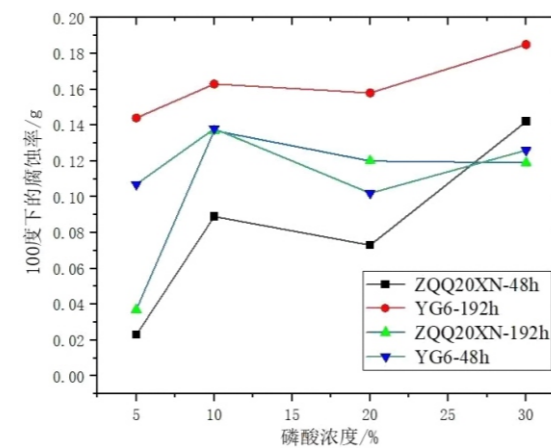
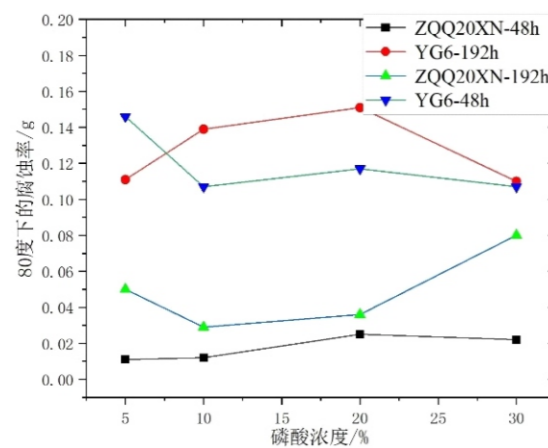
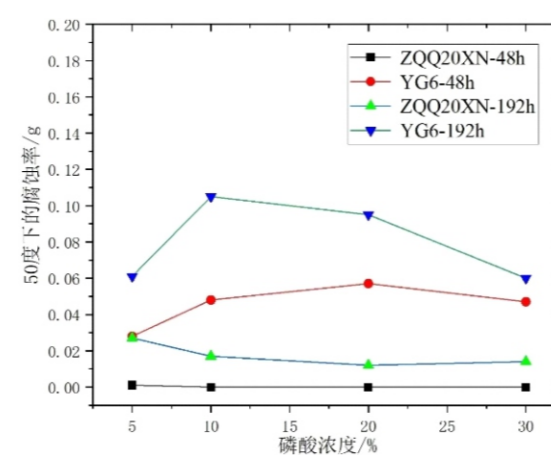
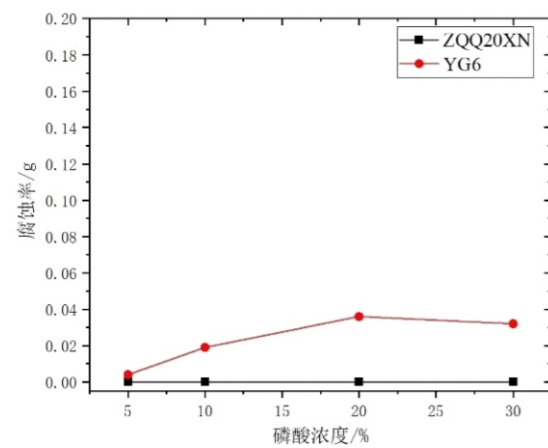

- The surface area of the ZQQ20 XN sample block in contact with acid is 1350mm<sup>2</sup>; The surface area of YG6 sample block in contact with acid is 370mm<sup>2</sup>, The calculation of the loss rate per unit area shows that the ZQQ20XN metal ceramic is only 3% to 10% of YG6 under the same corrosion conditions, and has a significant anti phosphoric acid corrosion effect.

# Ti-BASED CERMET SPRAY POWDER

Titanium based metal ceramic spray powder is prepared by agglomeration sintering. The spray powder has uniform composition and agglomerated sintered particles are spherical or nearly spherical. The usage temperature can reach 500 °C – 1000 °C. The spray powder has stable flowability and binds to the surface of the base metal at ≥ 70MPa.

## Performance Advantages

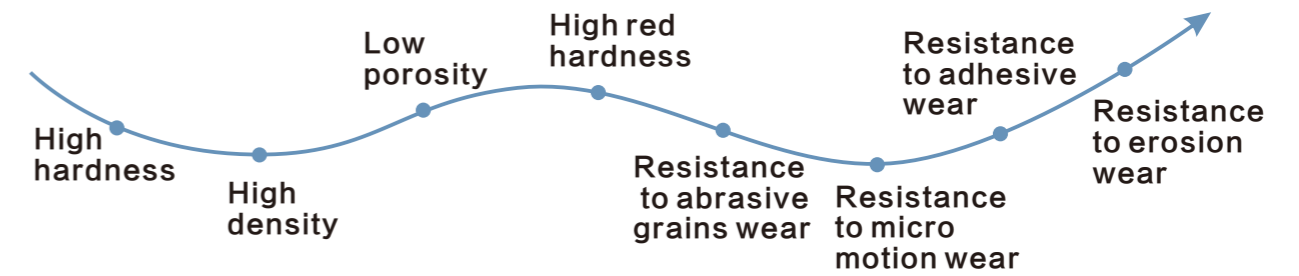

## Application Scenario

It can be widely used for high-temperature and wear-resistant surface spraying of aircraft landing gear, extrusion molds, wire drawing equipment, paper rollers, glass industry, crushing rollers, pump sealing components, etc.

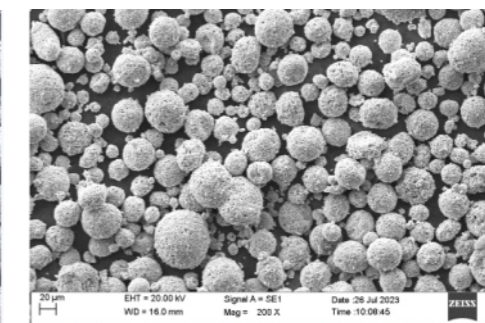
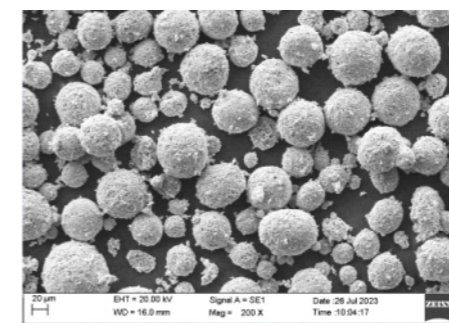

200x SEM spherical morphology image

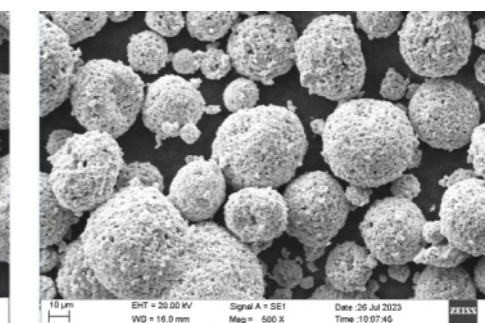
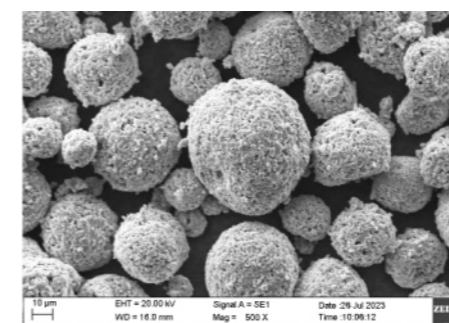

500x SEM spherical morphology image

# Ti-BASED CERMET WEAR RESISTANT PARTS

## Product Description

ZQQ20XN grade is a cermet material with very good comprehensive performance, and it is a grade that achieves an excellent balance between wear resistance and impact toughness.

It is widely applicable to all kinds of drawing dies and cold drawing dies.

In dry friction, an extremely thin TiO<sub>2</sub> film is formed on the surface of the cermet, which acts as a self-lubricating surface. The friction coefficient is only 1/3~1/2 of that of conventional cemented carbide materials. Especially at high temperatures, it has excellent performance. Excellent oxidation resistance, small temperature deviation, uniform heat conduction, and the service life of parts is obviously 2~3 times longer than that of cemented carbide.

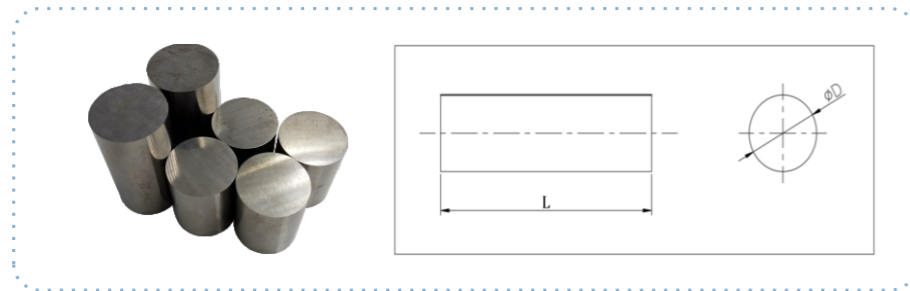

## Product Dimension

Provide cermet blanks or finely ground punch rods according to customer needs, the specific dimensions are as follows:

Dimension		Diameter	
φD	L+0.6/+1.2	Blank	Fine Grind
14	0~100	+0.5/+0.8	h6
15	0~100	+0.5/+0.8	
17	0~100	+0.5/+0.8	
20	0~100	+0.5/+0.8	
22	0~100	+0.5/+0.8	
25	0~100	+0.5/+0.8	
28	0~100	+0.5/+0.8	
30	0~150	+0.5/+0.8	
32	0~150	+0.5/+0.8	
34	0~150	+0.5/+0.8	
50	0~150	+0.5/+0.8	
... ..	... ..	... ..	

## Cermet Bushing/sleeve

ZQQ20XN grades are suitable for bushings/sleeves of various pumps, such as oil (water) equipment, motors of submersible (water) electric pumps, centrifugal pumps, protectors, rotary support, centering, thrust and sealing of separator shafts. Under this working condition, the low friction coefficient of the cermet and the self-lubricating characteristics of the titanium dioxide film on the surface have been greatly exerted in the wear resistance and corrosion resistance, and the service life of the pump has been significantly improved.



## High Wear-resistant Nozzle

ZQQ30XN grade is a cermet material for high wear resistance requirements, and its high temperature resistance, corrosion resistance and erosion resistance are stronger. It is especially suitable for small impact static wear-resistant conditions, such as the most widely used in high-pressure jet nozzles, and its service life is twice that of conventional tungsten carbide.

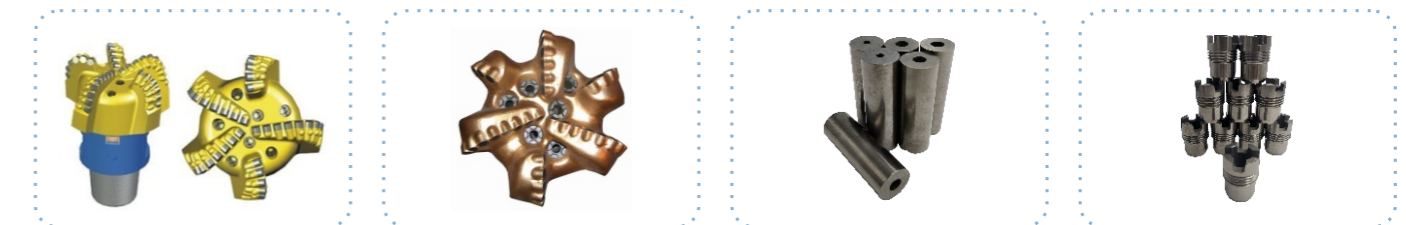

## Guide Rolls, Roll Rings For Steel Industry

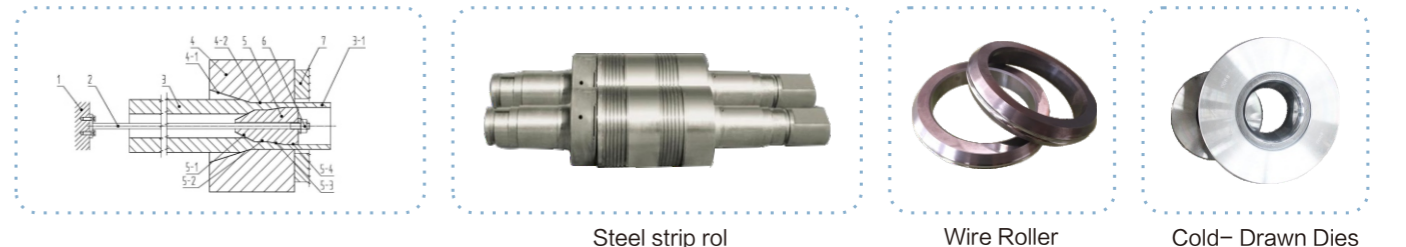

## Non-standard Shaped Parts

Zhaoqiang ZQQ10XN brand is a new high toughness low magnetic (non-magnetic) cermet material, which not only has good wear resistance and acid corrosion resistance, but also has high strength and good impact toughness. It is located in all kinds of complex special-shaped wear-resistant parts subject to frequent shocks and vibrations and wear-resistant parts that require a non-magnetic environment. The comprehensive performance is better than that of commonly used tungsten carbide, and the service life of the parts is significantly longer.



# Ti-Based Cermet Valve & Fittings

## Product Description

Valves and Pipe fittings are new products developed by the application of new material Ti (CN), which are mainly developed for the harsh working conditions of pipeline valves in the current petrochemical, coal chemical, polysilicon and other industries.

Compared with traditional structural valves, our products can effectively increase the service life of pipe valves, reduce the maintenance and repair costs of shutdown equipment, and improve

## Product Category

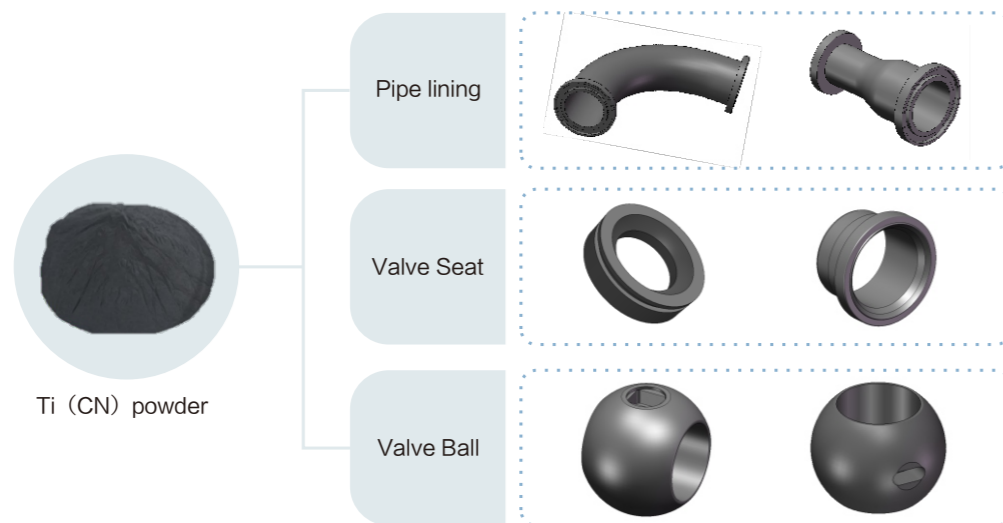

## Application Industry

Various acid, alkali, salt, gas, liquid, high-temperature steam, and mud transportation systems in industries such as petrochemicals, metallurgy, papermaking, power plants, refining, coal chemical, and new energy battery materials.

Lime water, limestone slurry, gypsum slurry for flue gas desulfurization and denitrification in thermal power plants, pneumatic ash removal in thermal power plants, pneumatic conveying of polycrystalline silicon powder, pneumatic conveying of metallurgical powder, wet metallurgical sulfuric acid and sand mixture, etc.

## Application medium

Sulfuric acid, hydrochloric acid, lime water, gypsum slurry, black water, grey water, etc. containing solid particles; Silicon powder, coal powder and other high wear, high corrosion, dry powder medium.



## Ti-Based Cermet-Fixed ball valve

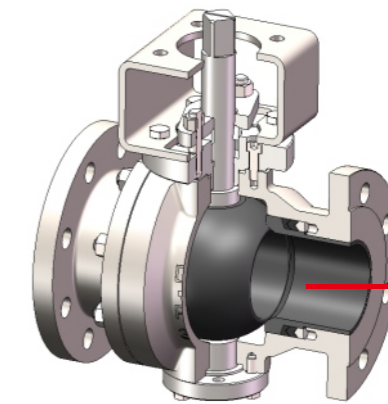
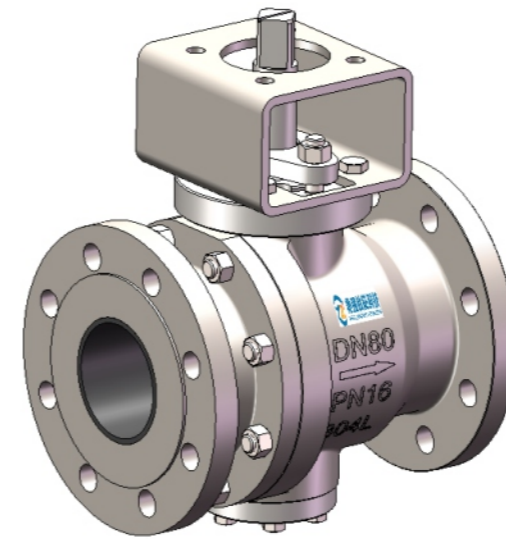

Valve ball · valve seat · liner are all made of Ti-based cermet

## Ti-Based Cermet-Floating ball valve

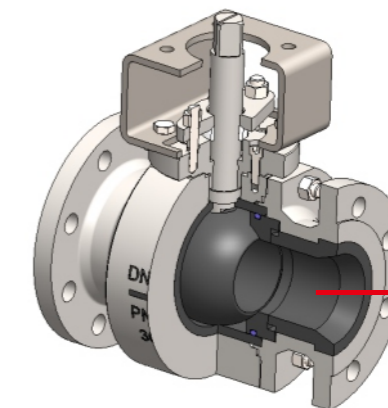
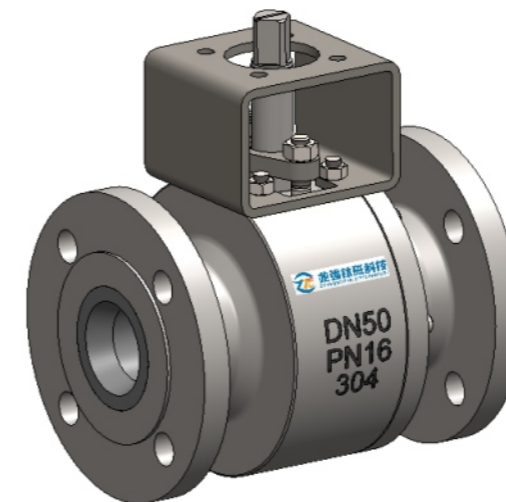

Valve ball · valve seat · liner are all made of Ti-based cermet

## The magnetic fluid seal valve

The magnetic fluid seal valve replaces the existing valve stem packing seal (PTFE, flexible graphite, O-ring, etc.) with a magnetic fluid seal structure.

It can solve the valve leakage caused by the wear of the packing seal and the reduction of the pre-tightening force of the packing pressure ring after a period of use. Especially for high-risk medium, it can reduced operating torque, and has longer service life.

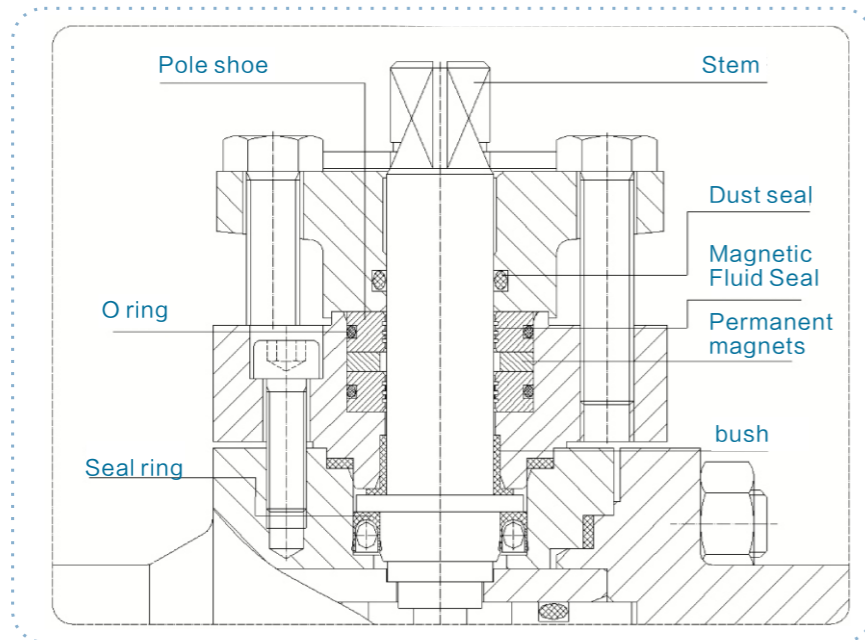

### Product Design & Simulated Analysis

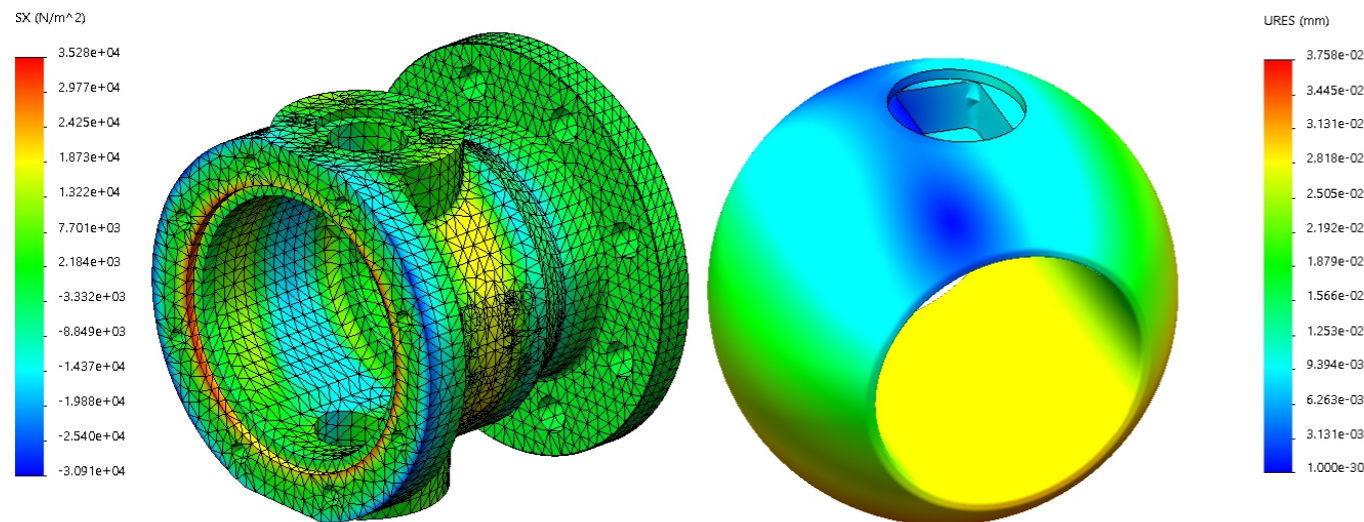

## Ti-Based Cermet Pipe Lining

### Product Description

Compared with fluorine-lined and ceramic-lined pipes, the flange pipe fittings developed and designed by Ti-Based cermet materials have longer life, more wear resistance, higher temperature resistance, more corrosion resistance, and higher negative pressure resistance.

The pressure rating of the flange pipeline is the national standard nominal pressure PN16/PN25/PN4.0, and the American standard ANSI 150LB/300LB. Flange standard: HG/T20592, ANSIB16.5, etc., can also be customized according to user requirements.

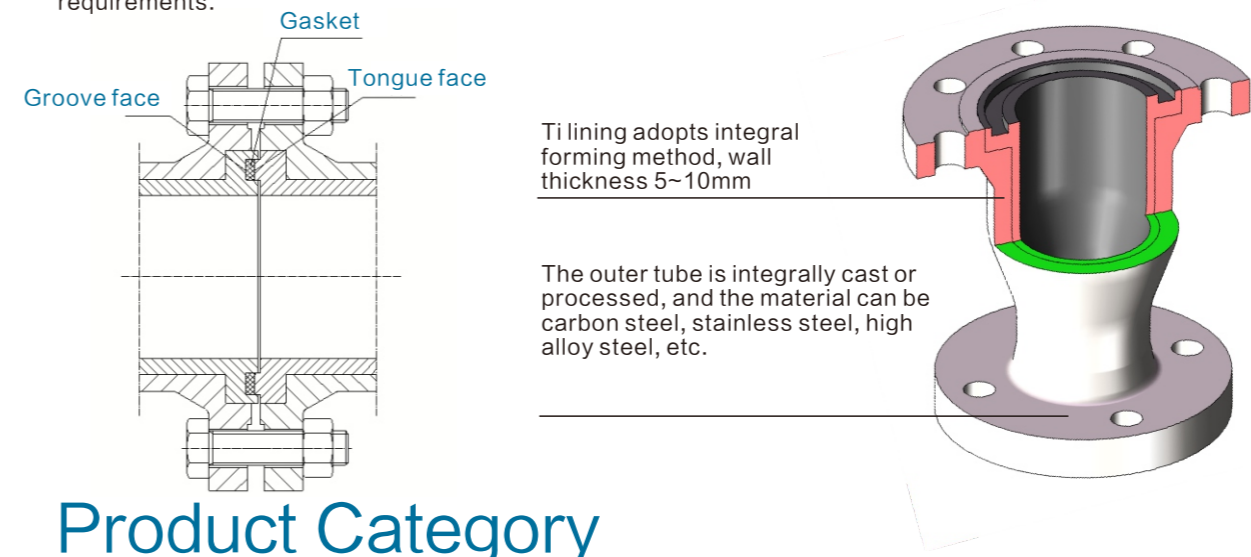

### Product Category

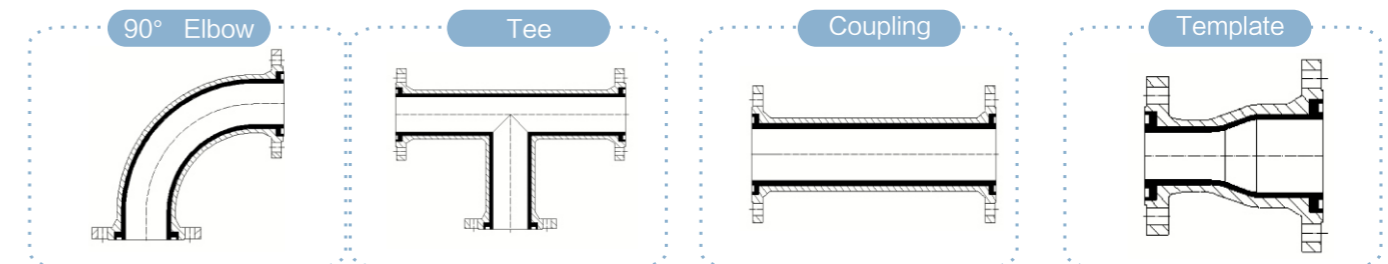

## NON-STANDARD CUSTOMIZATION Cermet non-standard customization

Our company has a strong ability to develop new products for wear-resistant parts, and has a very deep technical accumulation in the research and application of Ti(CN)-based cermets, which can assist customers in manufacturing reliable cermet products suitable for different working conditions.

### Notes

- Ti-based cermets should be fully cooled during the subsequent deep processing and grinding process to avoid cracks due to the heat concentration of the material due to insufficient cooling.
- Ti-based cermets should be fully cooled during grinding. The grinding efficiency of traditional ordinary diamond grinding wheels is lower than that of carbide grinding. For specific grinding methods, please consult our engineers.