



Sichuan Zhaoqiang Tai Ci Technology Co., Ltd.

Tel : 028-81185678

email : zhaoqiang@zqtckj.com

Web: <http://www.zqtckj.com>

Add: Maipu Building , NO.288, Tianfu 3rd Street, High-tech Zone, Chengdu City, Sichuan Province, China

 **Zhaoqiang Sealing**

Zigong Zhaoqiang Sealing Products Industrial Co., Ltd

Tel : 0813-3202675

Fax : 0813-3202675

Web: <http://www.zhaoqiangseal.com>

Email: Marketing@zhaoqiangseal.com

Add: No.66, No.19, Longxiang Avenue , High-tech Industrial Park , Zigong City, Sichuan Province, China



扫码关注



- THE SEAL TECH EXPERT - MAGNETIC FLUID SEAL



 Zero Leakage

 Non-wearing

 Self-repairing

 Long lifecycle

 High reliability

 Capable of high speeds

 Low friction coefficient

 Ensures high purity of medium

 Highly inclusive of Axis radial runout

- Sichuan Zhaoqiang Tai Ci Technology Co., Ltd. -

Company Profile

Sichuan Zhaoqiang Tai Ci Technology Co., Ltd. a high-tech enterprise specializing in magnetic fluid sealing and titanium-based metal ceramics technology, is dedicated to the research and development of new materials and devices. Its history dates back to the establishment of Zigong Zhaoqiang Sealing Products Industrial Co., Ltd. in 2000. Over twenty-four years of steady growth, the company has transformed into a leading new materials enterprise driven by technological innovation and group operations.

As a member of the China Mechanical Sealing Association, the company has been honored with titles such as National High-tech Enterprise and National Specialized and New "Little Giant" Enterprise. It has also obtained critical military certifications, including the National Defense Weaponry and Equipment Research and Production Certificate and the Confidentiality Qualification Certificate, demonstrating its significant capabilities and high level of trust in the military sector.

In terms of technological innovation, the company has received numerous prestigious awards, including the National Second Prize for Technological Invention and the First Prize from the China Invention Association, highlighting its outstanding achievements and innovative capabilities in scientific research. Additionally, the company has accumulated over 80 patents.

Our core business is centered on providing customers with zero-leakage, long-lasting magnetic fluid sealing solutions, and metal ceramic products that are wear-resistant, corrosion-resistant, and high-temperature resistant. We leverage innovation in material science and process technology as our primary competitive advantage, addressing key challenges and pain points encountered by our customers in their operations. Our mission is to help clients achieve comprehensive goals such as safety, environmental sustainability, burden reduction, and efficiency enhancement.

Our products have been widely adopted across various industries, including aerospace, defense, petrochemicals, mechanical metallurgy, power generation, steel production, chemicals, shipbuilding, new energy, new materials, pharmaceuticals, and food production. We have successfully built long-term, robust partnerships with numerous industry leaders, earning widespread recognition and trust from our clients.

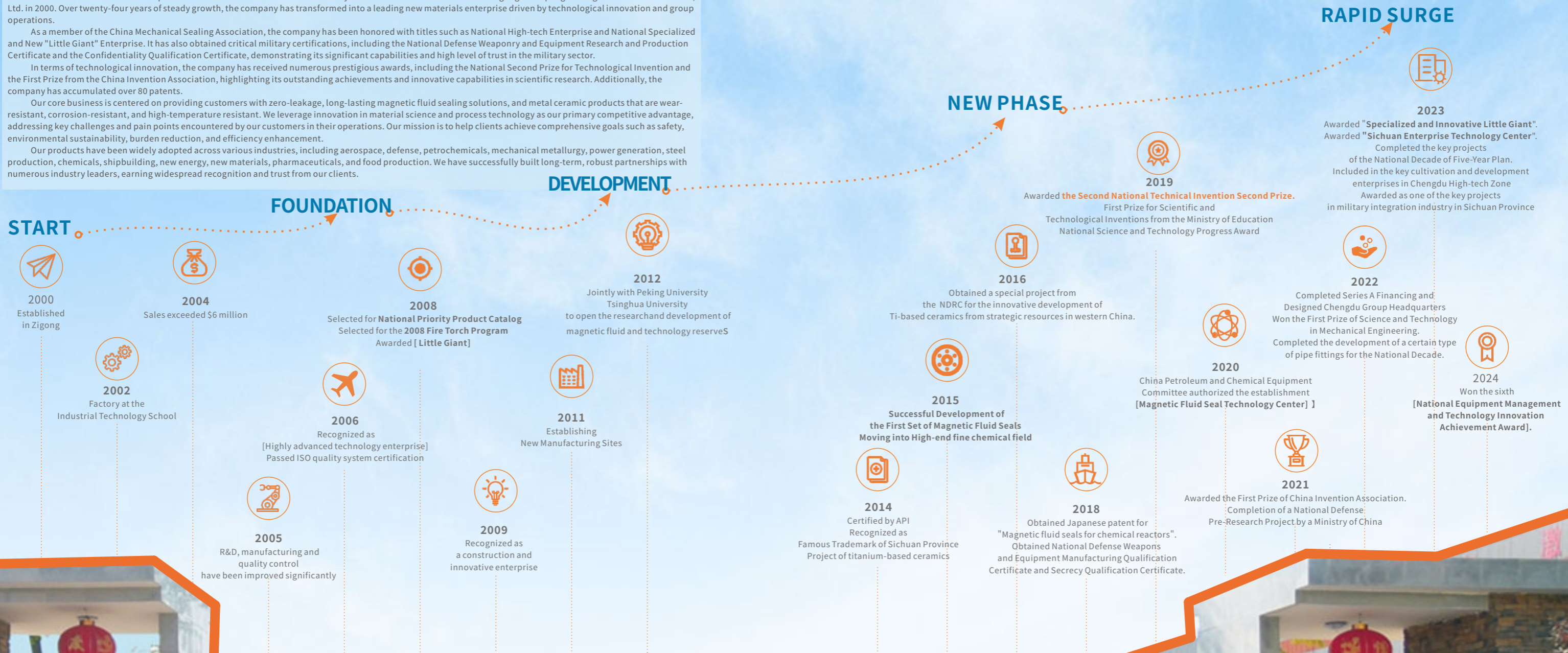

共建和谐 共谋发展 共创事业 共享价值



Enterprise Honor

30+

- ※ Second Prize of National Technical Invention
- ※ National Specialized and Innovative Little Giant Enterprise
- ※ Member of National Mechanical Seal Association
- ※ National High-tech Enterprise
- ※ National Torch Program
- ※ National Key Products Program



80+

- ※ 1 International PCT patent
- ※ 20 patents for inventions
- ※ 46 patents for Utility Models



中国石油	中国石化	中海石油	延长石油	中国国电	中船重工
中国铝业	WANHUA	华鲁恒升	滨化股份	多氟多	鲁抗
HENGYI	通威集团	攀钢集团	宽福蓝天	长江电力	山东能源集团
		COOPERATIVE PARTNER			
恒力集团	JINCHUAN 金川			Morimatsu	AAA 长城搅拌
		COOPERATIVE PARTNER			
中泰化学	豪迈集团			HUAYUAN 华谊集团	HUAYUAN 华谊集团
新疆天业	华东石化装备智能制造及再制造产业园	中昊晨光	TIANHUA	SPXFLOW	DALIAN SATAKE
中国科学院	中国科学院高能物理研究所	中国电子科技集团公司	中国核电	清华大学	南开大学
浙江大学	四川大学	西南石油大学	昆明理工大学	重庆大学	四川轻化工大学

Magnetic Liquid

Magnetic Fluids are a new type of functional material, which is a stable colloidal solution formed by uniformly dispersing nanoscale magnetic solid particles in a carrier liquid. One of the most important applications of magnetic fluids is magnetic fluid sealing, which is realized by utilizing the response of magnetic fluids to magnetic fields.

---Mr. Wang

(Academy of Science and Technology of China, expert in fluid sealing technology)
Tsinghua Garden, March 6, 2010

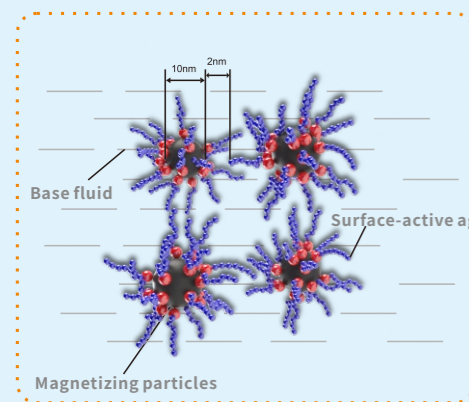

Composition of Magnetic Fluid

Magnetic fluids are composites of superparamagnetic nanoparticles coated with an active agent and dispersed homogeneously and stably in a liquid matrix, which do not aggregate or settle under magnetic force, eccentricity, or force of strength.

Components of Magnetic Fluids:

Base fluid: Silicone oil, fluorine ether, water, metal, etc. (different base fluids can be used depending on the field of application).

Magnetizing particles: Fe, Co, Ni, metal oxides, etc.

Surface-active agent: One end of the sub-chain is adsorbed to the magnetic particles and the other end must be well soluble in the carrier solution.

Characteristics of Magnetic Fluid

When there is no applied magnetic field, the nanoparticles in the magnetic liquid show chaotic Brownian motion, and the magnetization quantities cancel each other out, so that they do not show magnetic properties macroscopically; when a certain magnetic field is applied, the magnetic nanoparticles are aligned along the direction of the magnetization line of the external magnetic field, and then the magnetization quantities of the magnetic nanoparticles are no longer zero, so that they show strong magnetic properties. Therefore, by controlling the applied magnetic field, the distribution of the particles can be controlled in order to control the magnetic properties of the magnetic fluid.

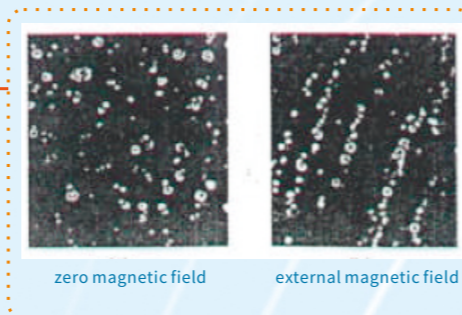

Magnetic Fluid Applications	
Fields of Application	Related applications
Mechanical industry	Mechanical shaft seals, sensors, speakers
Biomedical industry	Magnetic separation, drug release, magnetic resonance imaging, magneto-thermal cancer treatment, etc.
Aerospace industry	Seals for spacesuits, magnetic fluid deformable mirrors, and satellite vibration dampers.
Automotive industry	Damping dampers for suspension systems such as seats, as well as brakes and engine mounts.
Information Industry	Computer disk drive rotary shaft seals and inkjet printing systems.
Construction Industry	Earthquake and hurricane impact protection for buildings

Magnetic Liquid Seal

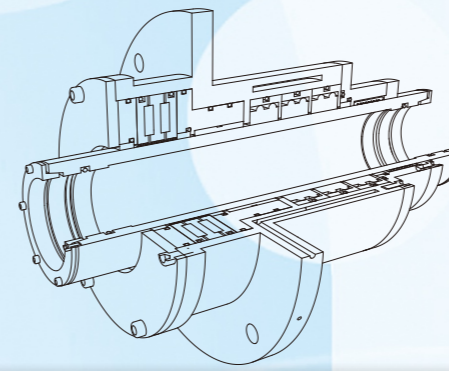

Magnetic seals offer tight sealing, unmeasured leakage rates, long life, high reliability, no contamination, high rotational speeds, optimum torque transmission, and low viscous friction. Because of this, magnetic seals play an important and irreplaceable role in many industries.

-Du Youwei

(Member of the Chinese Academy of Sciences, Magnetism and Magnetic Materials Scientist)
Nanjing, February 2010

Magnetic fluid sealing technology is a technological revolution in the traditional sealing industry and is recognized worldwide as a "zero-leakage" sealing technology. Magnetic fluid seals utilize a rotating magnetic field circuit between a magnet, a magnet-conducting shoe and a magnet-conducting shaft sleeve to attract magnetic fluid firmly between the tip of the shoe and the shaft sleeve, forming an O-ring-like fluid ring that completely closes the gap and achieves the sealing purpose. Magnetic seals are widely used for sealing toxic, hazardous, flammable and explosive substances, liquids and powders, as well as for vacuum sealing and media isolation.

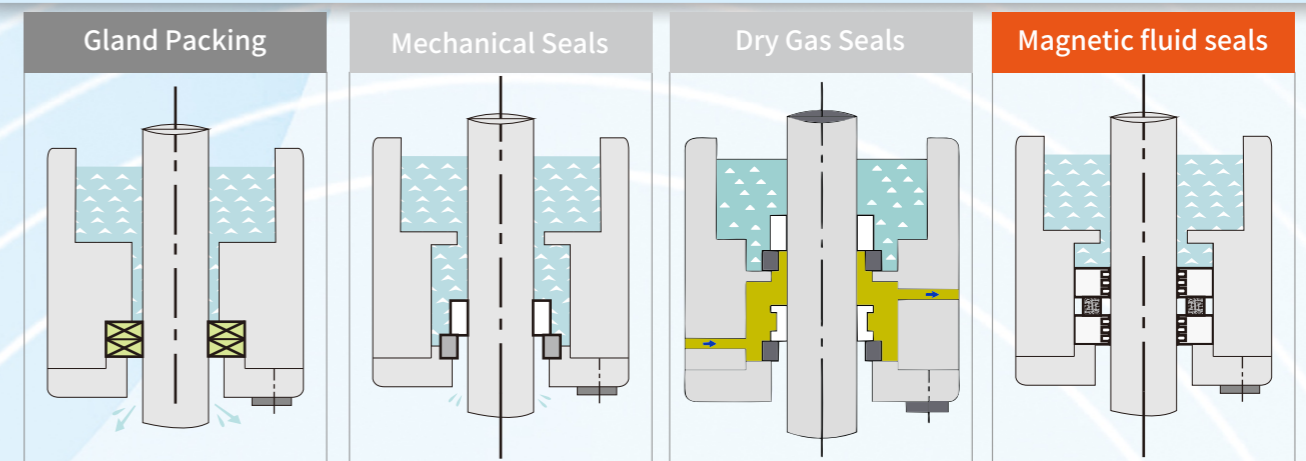

To prevent wear and high temperatures, leakage must be prevented.

A small amount of leakage is required to maintain lubrication of the liquid film.

Usually a two-stage seal requiring an auxiliary system.

No leakage.

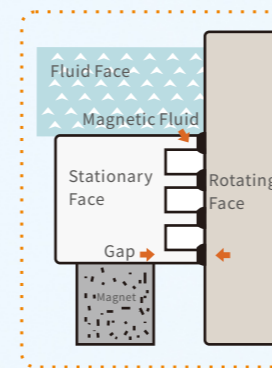

Essentials of Magnetic Fluid Seals

- The sealing gap is filled with a magnetic fluid. With the use of a magnetic force, the magnetic fluid is able to withstand the pressure from the media side, so that the sealing medium cannot leak out.
- There is no wear and tear on the stationary side or the rotating side, which greatly extends the life of the magnetic fluid seal and makes it more reliable than conventional mechanical seals.
- It is suitable for leakless sealing under reciprocating conditions, solving the problem of difficult reciprocating sealing of traditional seals.

Magnetic Liquid Seal Principle of construction

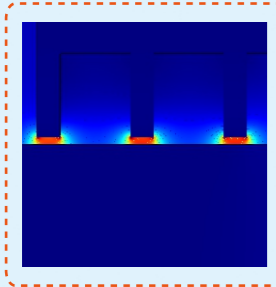
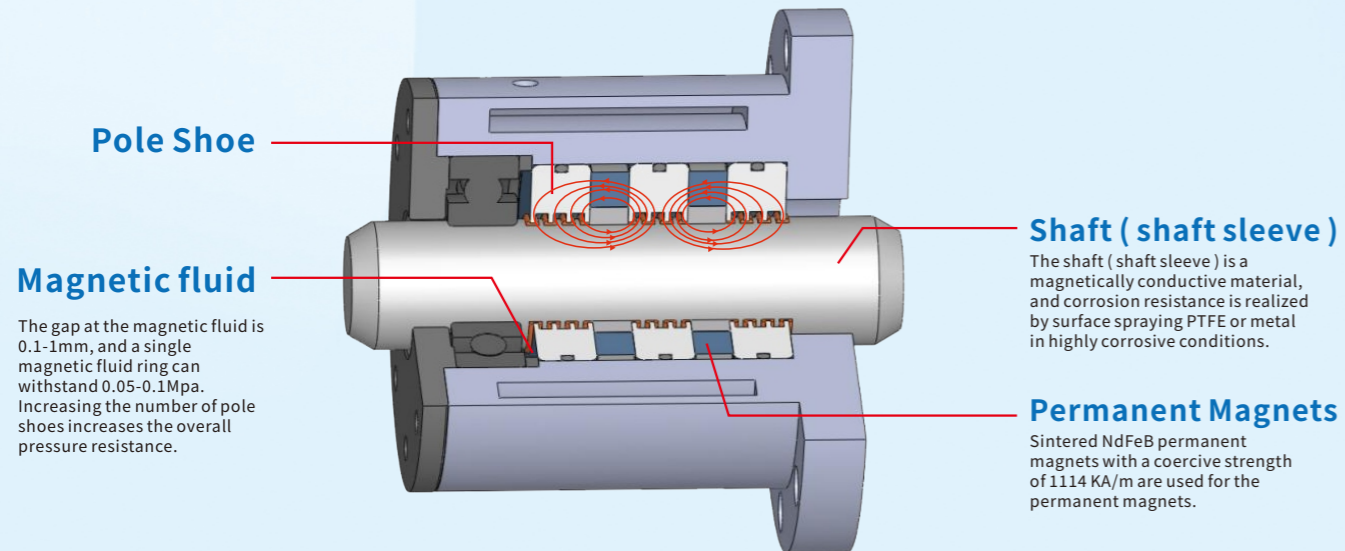

Magnetic Inductance Distribution

- The magnetic force is concentrated between the pole of the pole shoe and the shaft (shaft sleeve) so that the magnetic induction is maximized to ensure the strength of the seal.
- Depending on the working conditions, the overall sealing power can be increased by increasing the number of pole shoes.

Applicable working conditions:

- Shaft diameter**: >1mm
- Temperature**: -70°C~650°C (lower temperature when heating is permitted)
- Pressure**: 10⁻⁶Pa - 2.5MPa (up to 10Mpa with pressure-relief system)
- Linear velocity**: 0-41m/s
- Media**:
 - Various organic and radio-phase media;
 - Solid or liquid media that can be isolated by the body (except for large viscosity liquids, such as molasses);
 - Mixing of gases, solids and liquids or any two of them;
 - Vacuum or ultra-high vacuum seals;

Applicable industries



• Magnetic fluid seals can also be used in a wide range of industries, including metallurgy, pesticides, paper making, and pharmaceuticals.

Applicable Equipment:



• Magnetic fluid seals can also be used in vertical pumps, Roots machines, thin film evaporators, and many more.

ZQMF1F Magnetic liquid seal seal-agitator/vertical pump

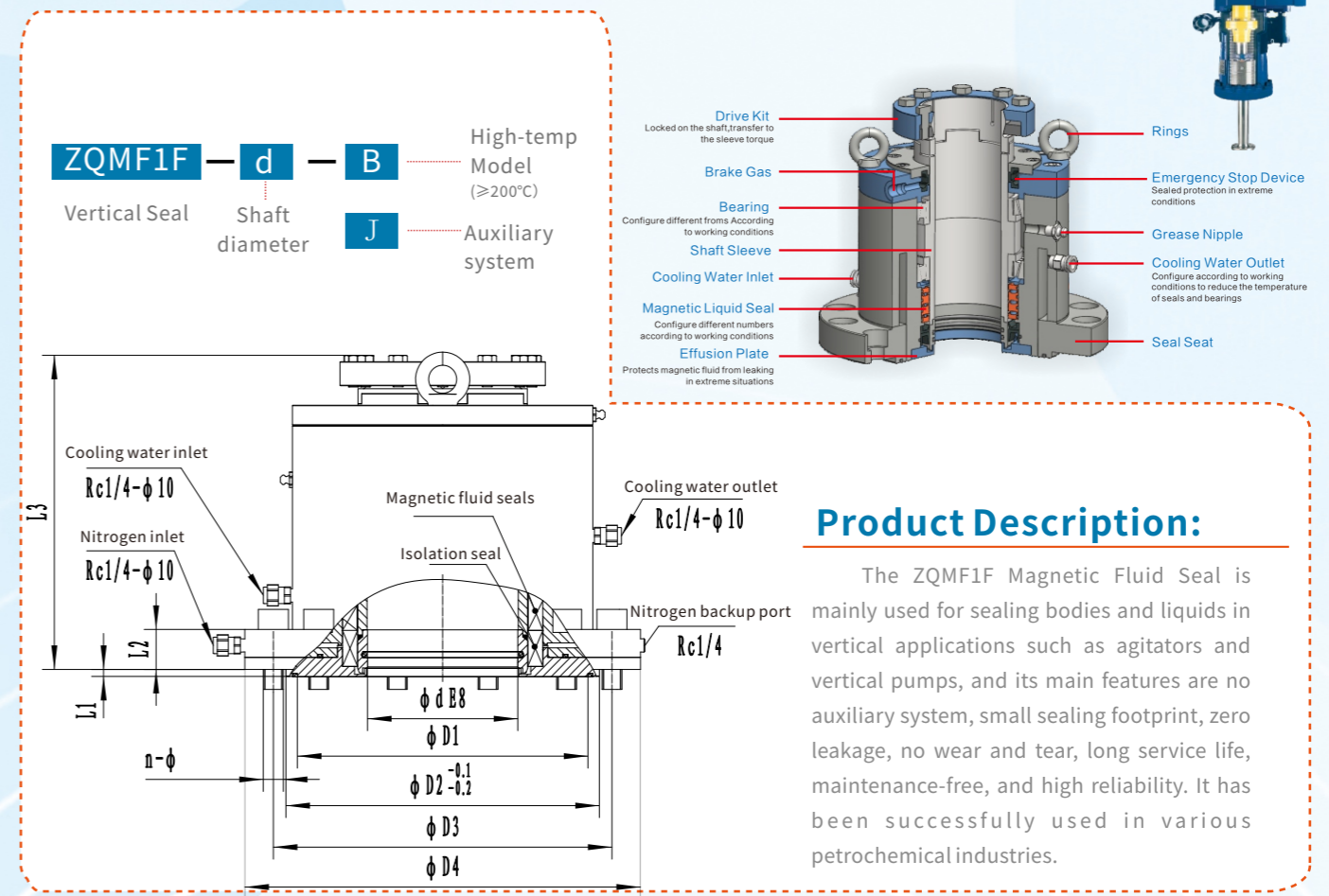

Product Description:

The ZQMF1F Magnetic Fluid Seal is mainly used for sealing bodies and liquids in vertical applications such as agitators and vertical pumps, and its main features are no auxiliary system, small sealing footprint, zero leakage, no wear and tear, long service life, maintenance-free, and high reliability. It has been successfully used in various petrochemical industries.

ZQMF1F Dimension Table

d	D4	D3	D2	D1	L1	L2	L3	Stud hole	
								n	Φ
30	175	145	110	90	5	40	220	4	18
40	175	145	110	90	5	40	225	4	18
50	240	210	176	150	5	40	225	8	18
60	240	210	176	150	5	40	230	8	18
70	240	210	176	150	5	40	240	8	18
80	275	240	204	180	7	40	245	8	22
90	305	270	234	210	7	40	255	8	22
100	305	270	234	210	7	40	270	8	22
110	330	295	260	240	7	40	285	8	22
120	330	295	260	240	7	40	290	8	22
130	330	295	260	240	7	40	290	8	22
140	395	350	313	290	7	40	305	12	22
150	395	350	313	290	7	40	315	12	22
160	395	350	313	290	7	40	340	12	22
170	395	350	313	290	7	40	340	12	22
180	445	400	365	310	7	40	350	12	22
190	445	400	365	310	7	40	360	12	22
200	530	460	365	310	7	40	370	12	22

P.S. Please contact us for special conditions and sizes.

ZQMF2F magnetic fluid seal Fan | Air Compressor

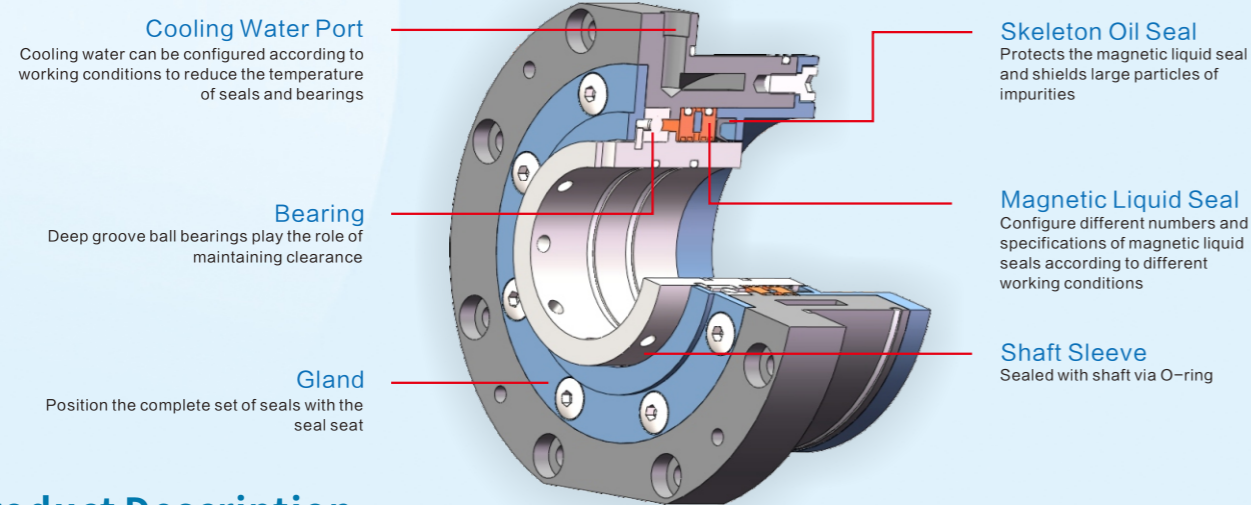

Product Description

ZQMF2F magnetic fluid seals are mainly used for horizontal gas seal in fans, compressors, and air compressors, etc. The main features of these seals are small sealing occupation, zero leakage, no wear and tear, long service life, maintenance-free, and high reliability. It has been successfully used in various petrochemical industries.

ZQMF2F magnetic fluid seal Liquid ring vacuum pumps

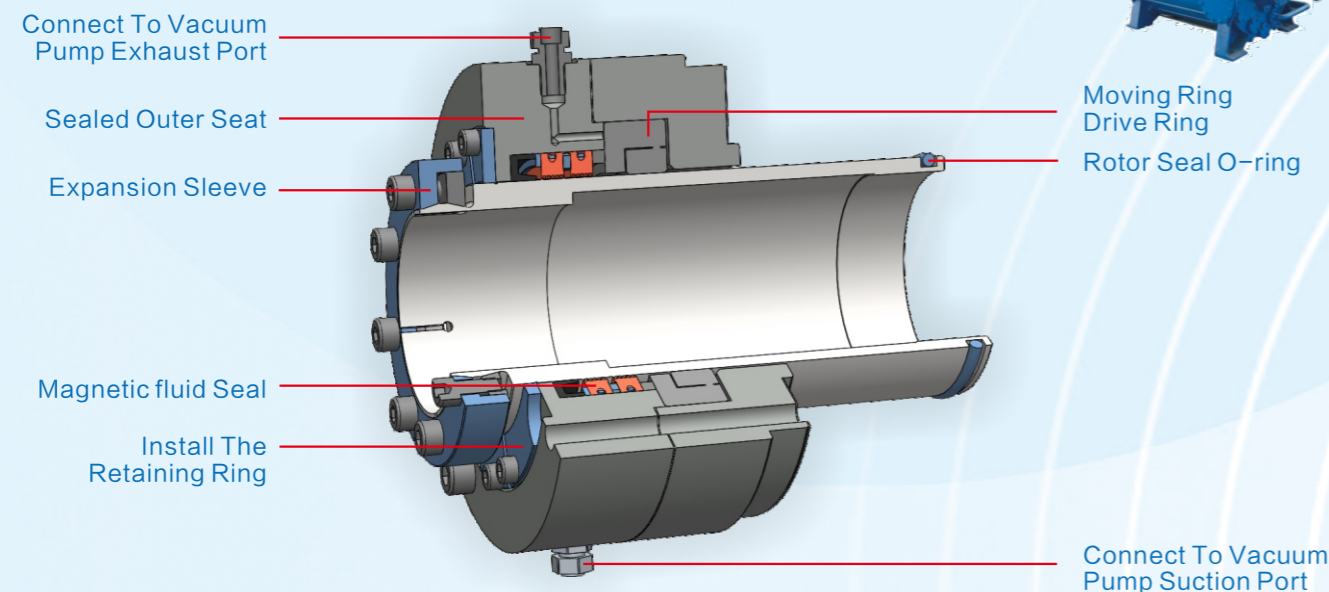

Product Description

The ZQMF2F Magnetic Fluid Seal is used to seal the rotor shaft of a vacuum liquid ring pump. The inner side of the magnetic fluid seal is connected to the vacuum pump inlet, and the small amount of leaking fluid from the single-face seal is transferred back to the

ZQMF3F Magnetic Liquid Face Seal

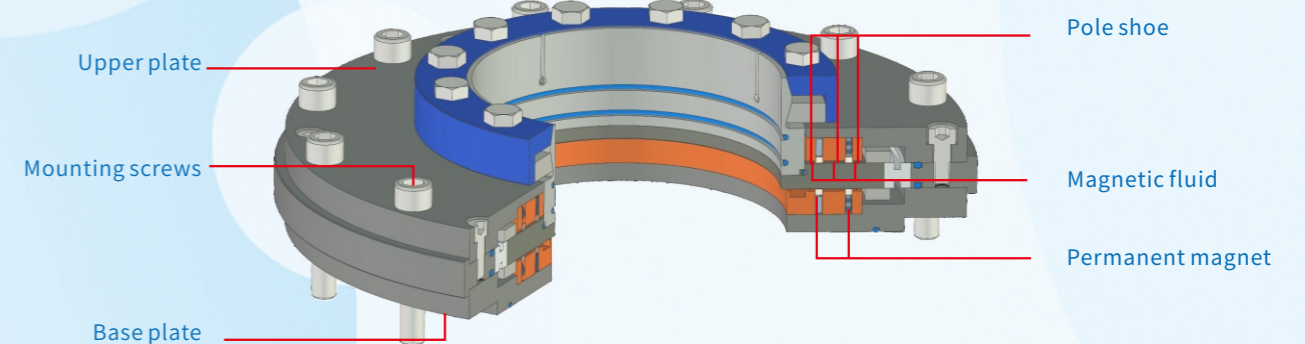

Product Description

The ZQMF3F end face seal consists of components such as a drive sleeve, rotating disc, upper plate, base plate, and a spacer ring. The rotating disc rotates synchronously with the drive shaft through the drive sleeve assembly. The outer end of the rotating disc extends radially along the drive shaft. The upper plate and the base plate are arranged radially along the drive shaft on the upper and lower ends of the rotating disc, respectively, forming pole teeth. The upper and base plates, together with the rotating disc, form a closed magnetic circuit. This creates an alternating strong and weak non-uniform magnetic field in the tooth-shaped gap, which tightly attracts the ferrofluid, forming an end face magnetic fluid seal structure between the upper and base plates and the rotating disc. This structure is compact, saving axial space and reasonably utilizing radial space. It avoids the problem of the sealing device being unable to be arranged due to axial dimension constraints.

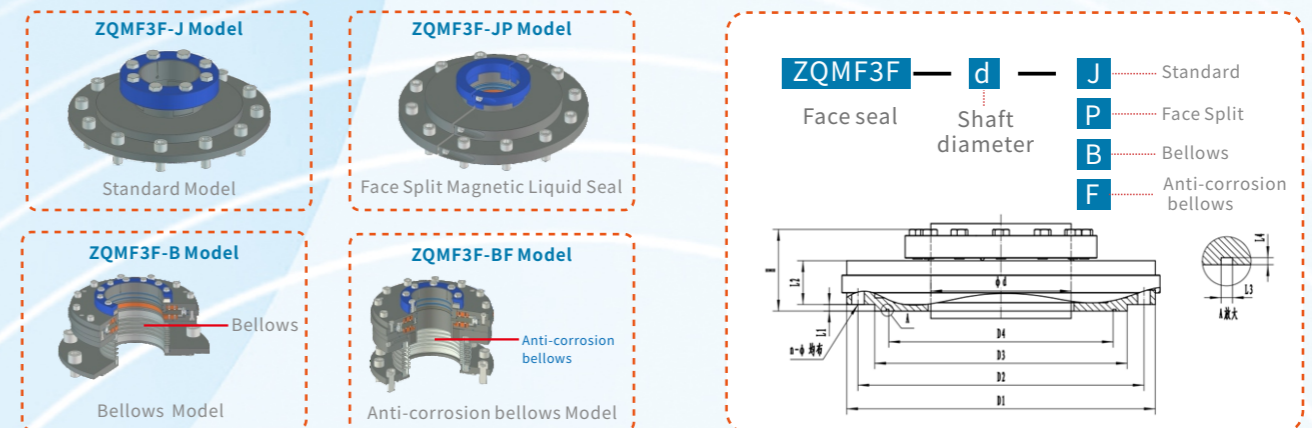

ZQMF3F Dimension Table															
d	D1	D2	D3 (H8/e7)	D4	L1	L2	L3	L4	H	H (B)	H (B-F)	H (J)	H (Jp)	Stud hole	
														n	Φ
30	175	145	110	90	5	18	3	1.9	100	150	200	90	80	4	18
40	175	145	110	90	5	18	3	1.9	100	150	200	90	80	4	18
50	240	210	176	150	5	18	3	1.9	100	150	200	90	80	8	18
60	240	210	176	150	5	24	3	1.9	100	150	200	90	80	8	18
70	240	210	176	150	5	24	3	1.9	100	150	200	90	80	8	18
80	275	240	204	180	7	28	4	2.7	100	150	200	90	80	8	22
90	305	270	234	210	7	28	4	2.7	100	150	200	90	80	8	22
100	305	270	234	210	7	28	4	2.7	100	150	200	90	80	8	22
110	330	295	260	240	7	28	6.5	4.1	120	170	220	100	90	8	22
120	330	295	260	240	7	28	6.5	4.1	120	170	220	100	90	8	22
130	330	295	260	240	7	28	6.5	4.1	120	170	220	100	90	8	22
140	395	350	313	290	7	28	6.5	4.1	130	190	220	100	90	12	22
150	395	350	313	290	7	28	6.5	4.1	130	190	220	100	90	12	22
160	395	350	313	290	7	28	6.5	4.1	140	200	240	110	100	12	22

P.S. Please contact us for special working conditions and dimensions.

Application Cases

Chemical Industry

Adipic Acid

In 2017, Zhaoqiang entered into a collaboration with a chemical enterprise located in Shandong to jointly implement a technological renovation that involved replacing the mechanical seals of the crystallizer agitators in their adipic acid plant with magnetic fluid seals. Prior to this, the mechanical seals used had an average lifespan of only 3 to 6 months. Considering that each crystallizer was equipped with 11 agitators, the frequent failure of the mechanical seals significantly impacted the stable operation of the plant.

Since switching to magnetic fluid seals, the plant has been operating smoothly for over three years without any seal failures, achieving a completely leak-free sealing performance and significantly extending the lifespan of the seals. Moreover, as magnetic fluid seals do not require additional auxiliary systems, we successfully eliminated the original mechanical seal auxiliary systems, thereby reducing potential failure points and maintenance costs. This renovation initiative has been highly praised and recognized by the user.



Project Conditions	
Equipment	Adipic Acid Crystallizer
Rotational Speed	800 RPM
Temperature	<70°C
Pressure	-0.08MPa
Medium	Nitric Acid, Adipic Acid
Shaft Diameter	75mm

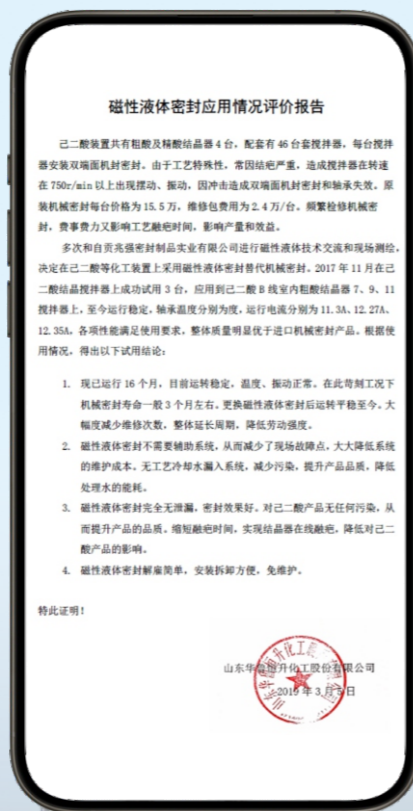

Fine Chemicals

LiPF6/Acrylic Acid/HDI

Since 2016, Zhaoqiang has established a close cooperative relationship with a globally operating chemical new materials enterprise. This company has a broad business scope, covering fields such as polyurethane, petrochemicals, fine chemicals, and emerging materials. During the cooperation, Zhaoqiang successfully implemented an innovative technological upgrade on the company's reactor units by replacing the original mechanical seals with magnetic fluid seal technology.

To ensure the stability and reliability of this technological upgrade, both parties conducted a comprehensive six-month operational trial, including pressure tests, temperature tests, long-term operational tests, remote alarm tests, and self-repair performance tests of the seals. The test results showed that all parameters remained within normal ranges, and no leakage incidents occurred throughout the trial period, fully validating the superiority and reliability of magnetic fluid seal technology.

Subsequently, Zhaoqiang further expanded the scope of the technology application by replacing the sealing components on various equipment, including the company's reactors and thin-film evaporators (vacuum). Practical application results indicated that these devices exhibited excellent operational performance after adopting magnetic fluid seals.



Pharmaceutical Industry

Antibiotics

In 2020, Zhaoqiang established a partnership with a well-known domestic comprehensive chemical pharmaceutical company. This company is not only a significant antibiotic production base in the country but also holds a prominent position in the Chinese pharmaceutical industry. For critical equipment in their cephalosporin production units, such as sterile crystallization tanks, we implemented technical improvements by replacing the original mechanical seals with magnetic fluid seals. Given that the company's product manufacturing process involves strong acidic and alkaline substances, the service life of traditional mechanical seals was severely affected. By introducing magnetic fluid seal technology, we successfully achieved zero leakage during the production process, significantly extending the equipment's lifespan.

Moreover, this technology effectively resolved the issue of contamination caused by debris from the friction of the original dry friction mechanical seals, ensuring a clean and stable production environment. More importantly, our solution fully complies with the safety standards of the pharmaceutical industry, earning high praise and recognition from the user.



Project Conditions	
Equipment	Sterile Crystallization Tank
Rotational Speed	800 RPM
Temperature	-10°C-135°C
Pressure	-0.1-0.35 Mpa
Medium	Acetone, Dichloromethane, Dimethylacetamide
Shaft Diameter	75mm



Application Cases

New Energy Industry

In 2023, Zhaoqiang established a partnership with a new energy company specializing in the research, production, and sales of lithium battery cathode materials. This company is the first in the country to successfully achieve large-scale production of NCM811 cathode materials. The company's ternary lithium battery agitators face significant challenges due to the 10-meter length of the stirring shaft, which leads to considerable oscillation during operation. This causes severe wear on the end faces of traditional mechanical seals, typically resulting in leakage problems within less than three months of use.

To address this technical challenge, our company introduced an innovative magnetic fluid sealing technology. This technology employs a novel end-face structural design, effectively coping with the large oscillations caused by the long stirring shaft. As a result, it significantly extends the service life of the sealing device, far surpassing the performance of traditional mechanical seals.



Cathode Materials



Photovoltaic Industry

In 2022, Zhaoqiang established a partnership with a polysilicon production company that focuses on the production of high-purity silicon materials and monocrystalline silicon rods. This company is dedicated to promoting the development of clean energy and aims to become a benchmark in the high-purity silicon and photovoltaic industries. During their production process, specifically in the slurry handling procedure of the dryer, we implemented magnetic fluid sealing technology to replace the traditional packing seal method. Given that the company's production media include hazardous gases such as chlorosilanes and hydrogen chloride, gas leakage incidents frequently occurred, and the packing box area experienced severe shaft wear, posing significant safety risks.

By introducing magnetic fluid sealing technology, we successfully achieved the goal of zero leakage, significantly enhanced the lifespan of the sealing system, and effectively reduced the frequency of daily maintenance work. This initiative not only ensured production safety but also improved overall operational efficiency, providing the company with a more stable and reliable production environment.



Polycrystalline Silicon

Performance

Industry	Equipment	Medium	°C	Mpa	Rpm
Nuclear Power industry	Agitator	Radioactive Gas	90	/	750
Pharmaceuticals industry	Crystallization Tank Agitator	Acetone, Ethyl Ester, Water Vapor	/	0.3	80
Chemical industry	Crystallizer Agitator	Nitric Acid, Adipic Acid	70	/	750
Chemical industry	Propylene Compressor	Compressor Gas	160	0.9	/
Chemical industry	Oxidation Reactor	Nitric Acid, Water, Dibasic Acid Mixture, Adipic Acid	/	0.15	41
Chemical industry	Crystallizer Agitator	Nitric Acid, Adipic Acid	100	-0.08	/
Chemical industry	Kenflo Liquid Ring Vacuum Pump	Ethylene Glycol	60	/	590
Chemical industry	Agitator	Solvents, Raw Materials, Water	/	-0.1/0.6	37~62
Chemical industry	Agitator	Lotion, Acetone, Water	/	0.5	1480/47
Chemical industry	Crystallizer Agitator	Nitric Acid, Adipic Acid	70	/	750
Chemical industry	Agitator	Hf, Pf5, Hcl	≈ 10	/	≈ 70
Chemical industry	Alkynylation Reactor	Formaldehyde, Acetylene, Nitric Acid	100	0.3	/
Chemical industry	Reactor	Ternary Media, Etc.	60	0.1	/
Chemical industry	Connect	Freon 134a	65	/	12
Fine chemical industry	Coagulation Tank Agitator	For Colloidal Particles, Water, Solvent Oil, Industrial Second Monster	/	0.2	150
Fine chemical industry	Agitator	Corrosive To Chloride Ions	/	0.15	100
Fine chemical industry	Crystallizer Agitator	Adipic Acid	120	-0.95	/
Fine chemical industry	Crystallizer Agitator	Adipic Acid	90	-0.08	/
Fine chemical industry	Reactor	Styrene, Ethylbenzene	140	/	16
Photoelectric industry	Agitator	Iodine, Potassium Iodide, Boric Acid (concentration 7%), Water,	/	0.2	30~60
Petrochemical industry	Agitator	Epoxy Resin	/	-0.1/0.6	100
Petrochemical industry	Crystallizer Agitator	Adipic Acid	90	-0.08	/
Petrochemical industry	Agitated Vessel	Thf, Ptme, Etc.	150	/	18
New energy industry	Agitator	Anhydrous Hydrogen Fluoride, Lipf, Lithium Fluoride	/	/	/
New energy industry	Agitator	Anhydrous Hydrogen Fluoride, Lipf	/	/	/
Chemical industry	Vacuum Paddle Dryer	Hp;LiPF6	50	/	5-13
New Energy industry	Rotary Kiln (1.6 meters)	Oxygen	1200	-0.05	/